

TITLE MINIATURE JACK	SPC. NO. HTJ-035-24	PAGE : 1 OF 7 DATE : 2004.07.07
--------------------------------	-------------------------------	--

SPECIFICATION

1. Standard atmospheric condition

Unless otherwise specified, the standard range of atmospheric conditions for making measurements and tests are as follows :

Ambient temperature : 5°C to 35°C

Relative humidity : 45% to 85%

Air pressure : 86kPa to 106kPa

If there is any doubt about the results, measurements shall be made within the following limits:

Ambient temperature : 20±2°C

Relative humidity : 60% to 70%

Air pressure : 86kPa to 106kPa

Operating temperature range : -25°C to 70°C

Storage temperature range : \triangle -25°C to 70°C

2. Electrical characteristics :

	Item	Condition		Specifications
1	Rated voltage/ Rated current	With resistive load		D.C.12V.1A
2	Contact resistance	Measurement shall be made at with small current 1000 Hz (100 mA or less)	Make contacts	30mΩ MAX.
			Break contacts	
			Slide switch contacts	50mΩ MAX,
3	Insulation resistance	A voltage of 500V D.C. shall be applied for 1 min. after which measurement shall be made. (For the insulation resistance test gauge refer to clause 6.)	Between the conductors which should not make contact under normal conditions.	100MΩ MIN.
			Between each terminal and insulated metal part.	

ISSUE	DATE	WRTN	CHKD	APVD	DESCRIPTIONS
	2004.07.07	陳樹民	夏正雄	楊仲民	
\triangle x 1	2006.07.09	鄭伍豐	夏正雄	郭遠峰	將焊錫溫度條件列入規範
\triangle x 2	2008.03.11	陸昌妹	夏正雄	郭遠峰	Modify the item 4.1
\triangle x 1	2012.06.19	劉秀慧	郭素玲	郭遠峰	Modify the item 4.2

TITLE MINIATURE JACK	SPC. NO. HTJ-035-24	PAGE : 2 OF 7 DATE : 2004.07.07
--------------------------------	-------------------------------	--

	Item	Condition	Specifications
4	Dielectric strength	500V A.C. (50 Hz to 60 Hz) for 1 min. Trip current : 2mA(For the insulation resistance test gauge refer to clause 6)	Without damage to parts, arcing or breakdown, etc.
		Between the conductors which should not make contact under normal conditions. Between each terminal and insulated metal part.	

3. Mechanical characteristics

	Item	Condition	Specifications
1	Operating force	Insertion and withdrawal force shall be measured after inserting and withdrawing 3 times by using a gauge of standard dimensions (refer to clause 6) .	2.94N~29.4N (0.3kgf~3.0kgf)
2	Terminal strength	A static load of 4.9N (0.5Kgf) shall be applied to the tip of the terminals for 1 min. in any direction. A load of 4.9N (0.5Kgf) shall be applied to the tip of the terminals for 1 min. in the axial direction. The set shall be subjected to 1 bent through an angle of 90° in the right and left directions of terminal thickness.	Without cracks or excessive looseness to the terminal. Electrical and mechanical characteristics shall be satisfied. Without play in terminal, etc. (preclude No.7)
3	Contact pressure	Contact pressure during the make contact shall be measured in the operation by using the minimum dimensional gauge. The contact pressure during the break contact shall be measured under the normal conditions.	The contact pressure between chip, ring, sleeve and the contact piece. The contact pressure with the make contact. 1N (102 gf) MIN.

4. Endurance characteristics

	Item	Condition	Specifications
1	Solderability	Temperature of solder : $\triangle 250^{\circ}\text{C} \pm 5^{\circ}\text{C}$ Time of dip : 3 ± 0.5 seconds Length of dip : 2 ± 0.5 mm (from top of terminal)	The soldered area shall be covered a minimum of 90% of the surface being immersed.

TITLE MINIATURE JACK	SPC. NO. HTJ-035-24	PAGE : 3 OF 7 DATE : 2004.07.07
--------------------------------	-------------------------------	--

Item	Condition	Specifications		
2 △ Resistance to Soldering Heat Test	Wave soldering Process	Electrical and mechanical characteristics shall be satisfied, and not show remarkable failure.		
	Profile Feature		Pb-Free Assembly	
			Topside PCB	Padside PCB
	Preheat -Temperature min -Temperature max -Time (ts min to max)		120°C (Ts1 max)	110°C (Ts min) 150°C (Ts max) 75 sec
	Peak/Classification Temperature		165°C (Tp1)	260°C ±5°C (Tp)
	Time within 5°C of actual Temperature (tp)			10 sec (within 2 times every time 2-3 sec)
	Time 25°C to Peak temperature			3 minutes max
	Wave Soldering Temperature Profile are as below			
	△ About the plastic properties , Please refer to the data sheet of plastic.			
	<p>Temperature</p> <p>Time</p> <p>----- Topside PCB</p> <p>———— Padside PCB</p>			
Soldering Iron Test		Same as Wave soldering Process		
Temperature of soldering Iron : 380±10°C Soldering time : 3±1 seconds				
Insertion force		1.96~29.4N (0.2~3kgf)		
Withdrawal force		1.96~29.4N (0.2~3kgf)		

TITLE		SPC. NO.	PAGE : 4 OF 7
MINIATURE JACK		HTJ-035-24	DATE : 2004.07.07
Item	Condition	Specifications	
3 Cold	The jack shall be stored for 96 hours at a temperature of $-25\pm 3^{\circ}\text{C}$ immediately after which measurement shall be made.	Dimensional requirements shall be satisfied. Electrical and mechanical characteristics shall be satisfied.	
4 Dry heat	The jack shall be stored for 96 hours at a temperature of $70\pm 2^{\circ}\text{C}$ immediately after which measurement shall be made.	Dimensional requirements shall be satisfied. Electrical and mechanical characteristics shall be satisfied.	
5 Damp heat (Steady state)	The jack shall be stored at a temperature of 40°C and a humidity of 90% to 95% for 96 hours. Then the jack shall be maintained at standard atmospheric conditions for 1 to 2 hours after which measurement shall be made.	Dimensional requirements shall be satisfied. Electrical and mechanical characteristics shall be satisfied.	

TITLE MINIATURE JACK	SPC. NO. HTJ-035-24	PAGE : 5 OF 7 DATE : 2004.07.07
--------------------------------	-------------------------------	--

	Item	Condition	Specifications																	
6	Composite temperature/humidity cyclic test	<p>The jack shall be subjected to 10 continuous cycles, each as shown in figure below. Then the jack shall be stored at standard atmospheric conditions for 24 hours for recovery, after which measurement shall be made.</p> <p>*Temperature shall be reduced from 25°C to -10°C within 30 minutes.</p> <p>*Humidity uncontrolled at a temperature less than 25°C</p>	<p>Dimensional requirements shall be satisfied.</p> <p>Electrical and mechanical characteristics shall be satisfied.</p>																	
7	Operating endurance	<p>Inserting and withdrawing shall be made by the following mating plug or standard dimension gauge, (Refer to Clause 6. grease applied) at a speed of 10 to 20 times / min. Measurement shall be made for every 500 times.</p> <table border="1" style="margin-left: auto; margin-right: auto;"> <tr> <td>3000 times</td> <td>Without load</td> </tr> <tr> <td>2000 times</td> <td>Rated resistance load</td> </tr> </table>	3000 times	Without load	2000 times	Rated resistance load	<p>Electrical and mechanical characteristics shall be satisfied.</p> <table border="1" style="margin-left: auto; margin-right: auto;"> <tr> <td rowspan="3">Contact resistance</td> <td>Make contacts</td> <td>50mΩ MAX.</td> </tr> <tr> <td>Break contacts</td> <td>50mΩ MAX.</td> </tr> <tr> <td>Slide switch contacts</td> <td>80mΩ MAX.</td> </tr> <tr> <td colspan="2">Insertion force</td> <td>2N~30N (0.2Kgf~3Kgf)</td> </tr> <tr> <td colspan="2">Withdrawal force</td> <td>2N~30N (0.2Kgf~3Kgf)</td> </tr> </table>	Contact resistance	Make contacts	50mΩ MAX.	Break contacts	50mΩ MAX.	Slide switch contacts	80mΩ MAX.	Insertion force		2N~30N (0.2Kgf~3Kgf)	Withdrawal force		2N~30N (0.2Kgf~3Kgf)
3000 times	Without load																			
2000 times	Rated resistance load																			
Contact resistance	Make contacts	50mΩ MAX.																		
	Break contacts	50mΩ MAX.																		
	Slide switch contacts	80mΩ MAX.																		
Insertion force		2N~30N (0.2Kgf~3Kgf)																		
Withdrawal force		2N~30N (0.2Kgf~3Kgf)																		

TITLE MINIATURE JACK	SPC. NO. HTJ-035-24	PAGE : 6 OF 7 DATE : 2004.07.07
--------------------------------	-------------------------------	--

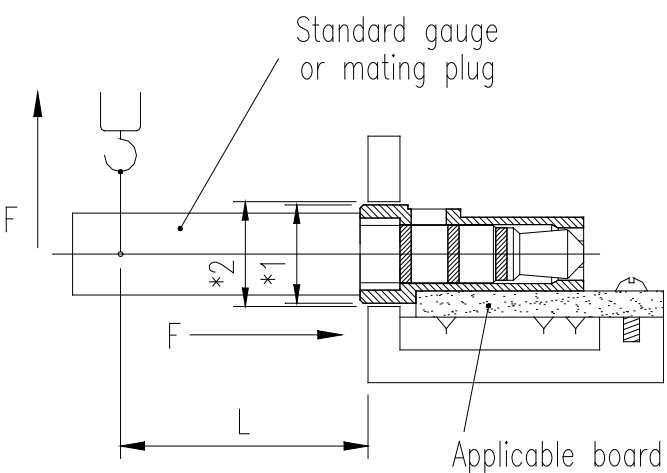
Item	Condition	Specifications						
8 Sulfuration	The terminals of miniature jack shall be dipped into a dilute solution of 3% potassium sulfide for 1 minute.	60mΩ MAX.						
9 Torsion strength	<p>The standard dimension gauge, (Refer to Clause 6) shall be fixed to the set in the actual used condition, Following plug shall be applied to horizontal and vertical directions to the jack each for 5 seconds. After which measurement shall be made.</p>  <p>*1 Outside dimension of jack *2 Outside dimension of jack + 0.3 mm</p> <table border="1" data-bbox="399 1366 1037 1467"> <thead> <tr> <th>Size</th> <th>L (cm)</th> <th>Condition</th> </tr> </thead> <tbody> <tr> <td>Mini (φ 3.5)</td> <td>2.5</td> <td>20N (2.04 Kgf)</td> </tr> </tbody> </table>	Size	L (cm)	Condition	Mini (φ 3.5)	2.5	20N (2.04 Kgf)	
Size	L (cm)	Condition						
Mini (φ 3.5)	2.5	20N (2.04 Kgf)						

5. FACTORY NAME : KUNMING ELECTRONICS (SHENZHEN) CO., LTD
 ADDRESS : NO. 1st Building NO. 10th Area Hua Wang Road, Da lang Village,
 Long Hua Town, Bao An Area, Shenzhen City, China.
 TEL : 86-755-8120255

TITLE MINIATURE JACK	SPC. NO. HTJ-035-24	PAGE : 7 OF 7 DATE : 2004.07.07
--------------------------------	-------------------------------	--

6 For $\phi 3.5$ Mini size

6.1. Standard dimension

Roughness of the surface:

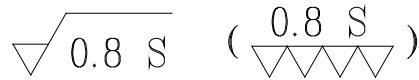

Materials: Stainless steel

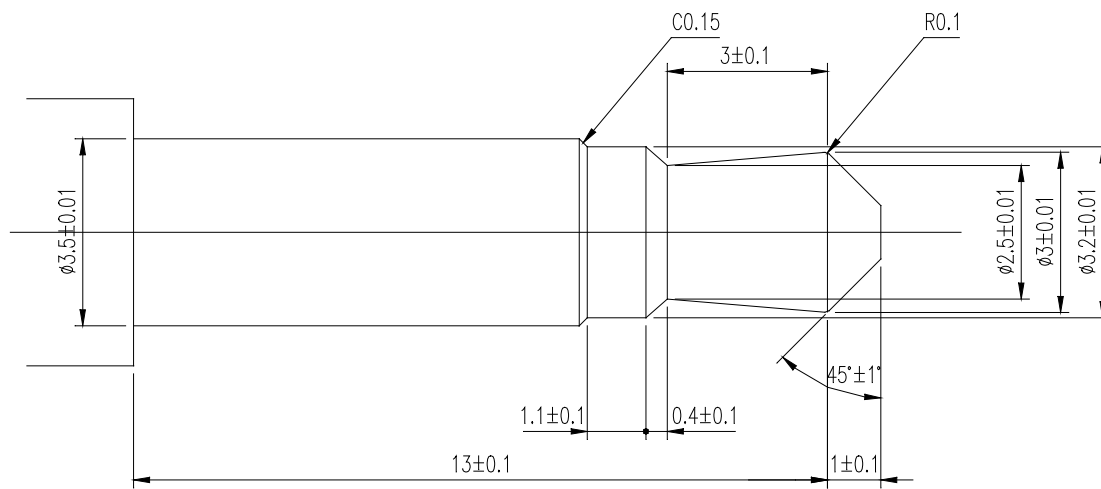

6.2. Mate plug:

4 points mini-plug

