

1 2 3 4 5 6

REVISIONS					
LTR	DESCRIPTION	DATE	REV.	CHKD.	APVD.
△x0	To modify the drawing by NO.F06160947	2016.05.24	陳衛兵	張啟濤	陳宗碧

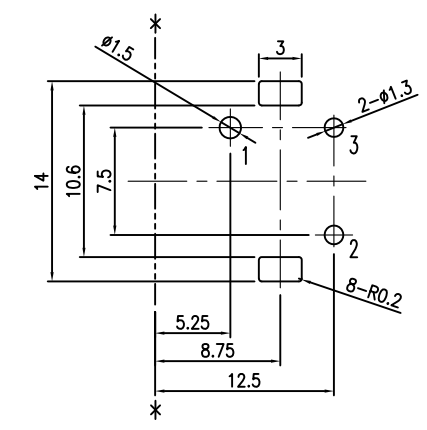

PCB Layout Dimension (Tolerance: ±0.10)  
(Recommend min. Dimension)(Bottom View)

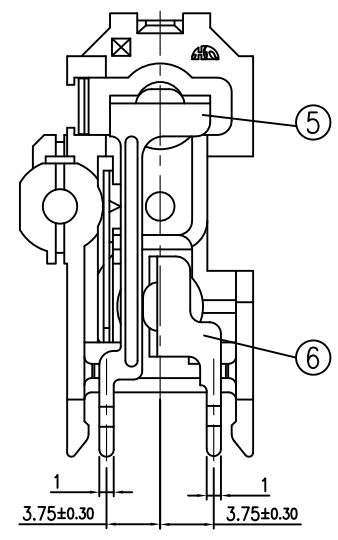
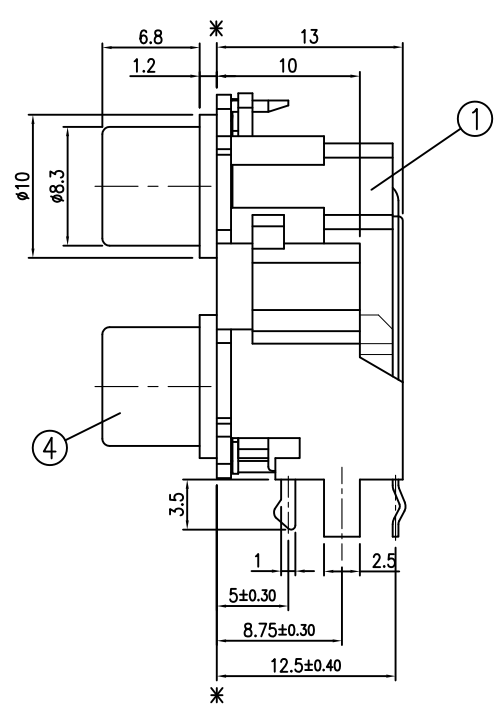
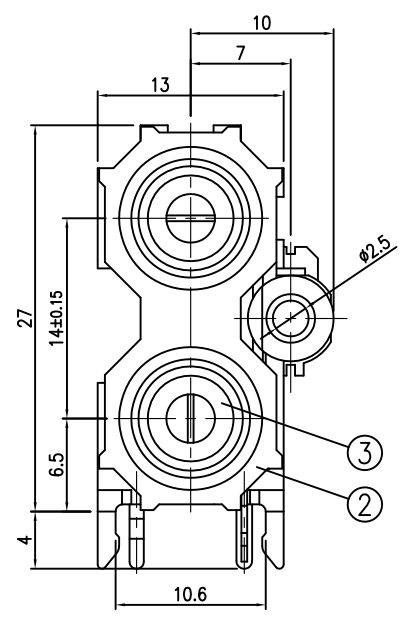
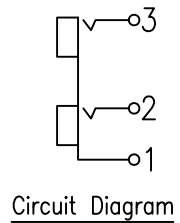
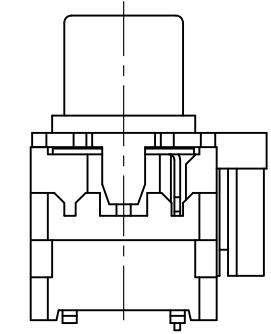

6	L-TERMINAL	1	Brass	t=0.40
5	S-TERMINAL	1	Brass	t=0.40
4	OUTER CONTACT-2	1	Brass	t=0.40
3	WASHER	1	PBT	UL 94V-0
2	COVER	1	ABS	UL 94HB
1	HOUSING	1	PBT	UL 94V-0

Please refer to color and plating combination list.

LTR	PART NAME	Q'TY	MATERIAL	REMARK				
0*	±2*	DWN	陳衛兵	DATE	2016.05.24	SCALE N/A	NAME	
0	±0.5	DSND	王子宏	DATE	2016.05.20			
0.0	±0.3	CHKD	張啟濤	DATE	2016.05.24	PROJECTION	CAT. NO.	
0.00	±0.1	APVD	陳宗碧	DATE	2016.05.24			UNIT:mm
DIMENSION TOLERANCE							KUNMING ELECTRONICS CO.,LTD.	
							DWN.NO.	1/1
							A-242V	D

The raw material specified by Sony should meet SS-00259 requirement of the latest version. When such material is used, it should be supplied by Sony designated suppliers.