

REVISIONS				
LTR	DESCRIPTION	DATE	REVISED	APPROVED
$\Delta$ X1	更改鍍層參照顏色料號表	2004.03.29	JOLLY	JOHNSON
$\Delta$ X4	更改材質,尺寸錯誤標註更正	2008.02.25	LORNA	ALLAN

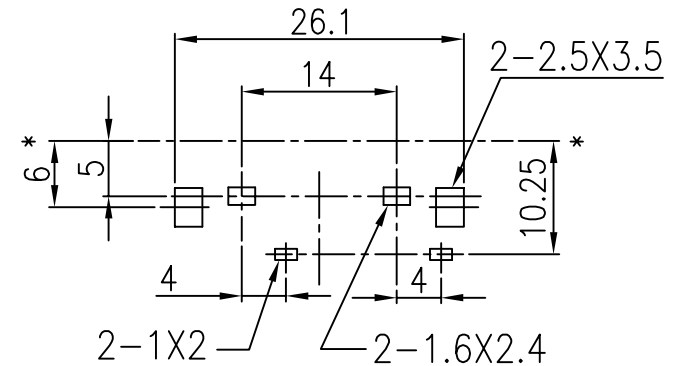
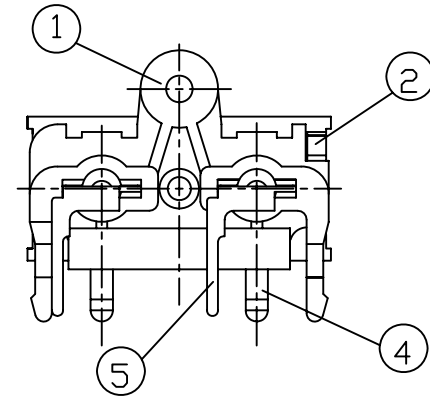
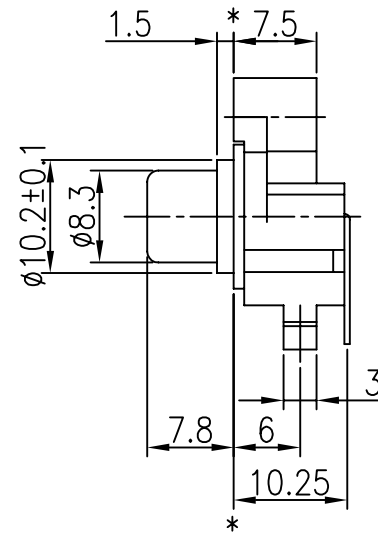
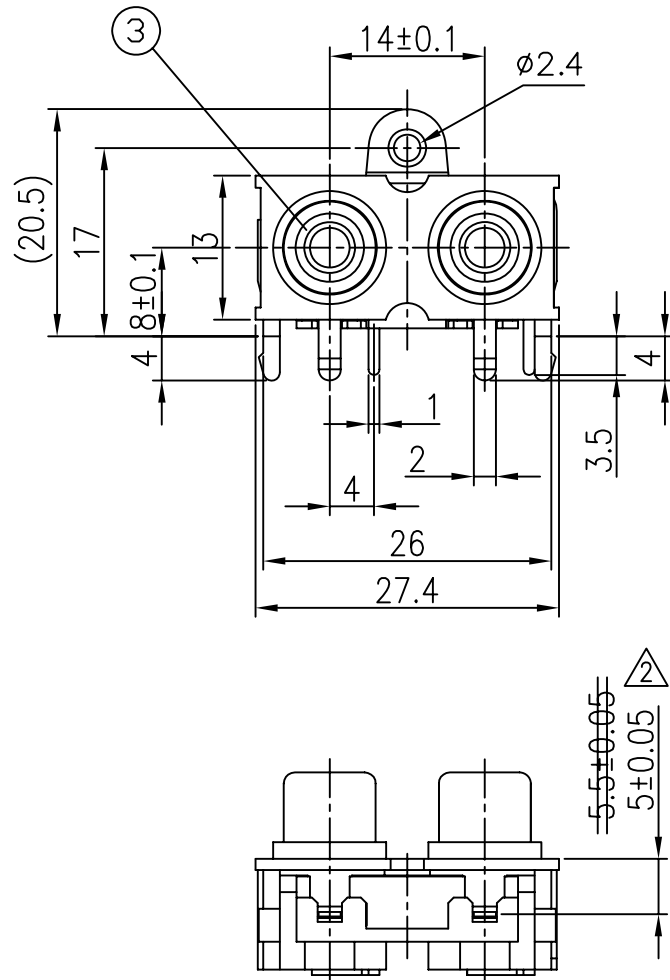

T:1.6 P.C.B Layout Dimension(Tolerance:±0.1)  
(Recommend min.Dimension) (Bottom View)

5	TERMINAL	2	C2680	t=0.5	$\Delta$ Please refer color combination list.	
4	OUTER CONTACT	2	C2680	t=0.5 $\Delta$ t=0.4		
3	SUB-BUSH $\Delta$ WASHER	1	ABS $\Delta$ POM, UL-94HB			
2	COVER	1	ABS	UL-94HB		
1	HOUSING	1	ABS	UL-94HB		
LTR	PART NAME	QTY	MATERIAL(THICK,COLOR)		REMARK	
DWN	LORNA	DATE	2008.02.25	SCALE /	NAME PIN JACK	
DSND	M.L.CHANG	DATE	1992.11.06	PROJECTION	CAT. NO. HSP-212V -	
CHKD	Qilin/ALLAN	DATE	2008.02.25	$\oplus$ $\nabla$		
APVD	BENSON	DATE	2008.02.27	UNIT: mm		
KUNMING ELECTRONICS CO.,LTD.					DWN.NO. A-212V	1/1 c

UNLESS OTHERWISE SPECIFIED, TOLERANCE ON DECIMAL: ±0.3 ANGLES: ±5°