

REVISIONS

LTR	DESCRIPTION	DATE	REV.	CHKD.	APVD.

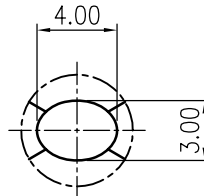

Detail A
Scale:1:2

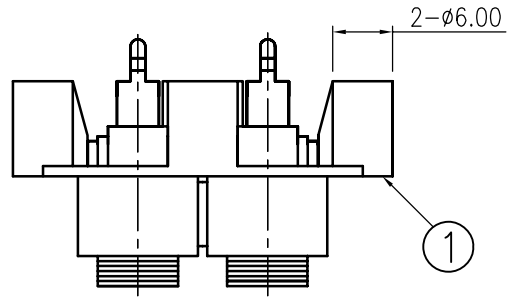
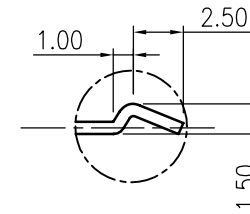

Detail B
Scale:1:2

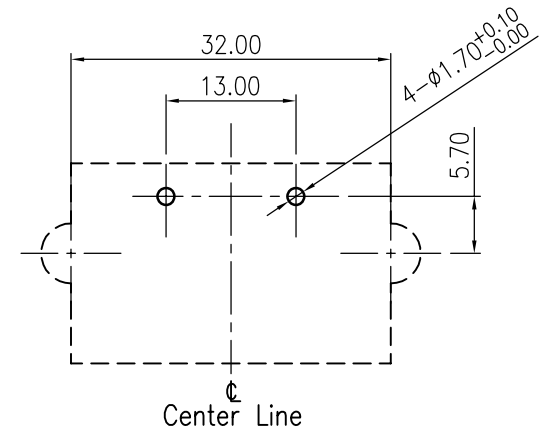
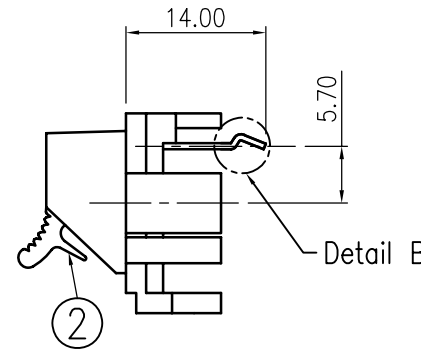
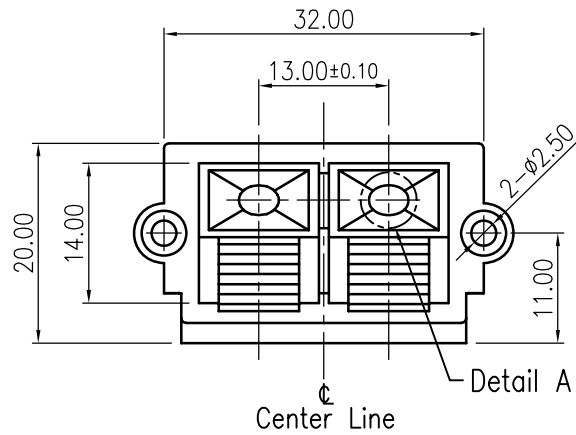

P.C.B Layout Dimension (Tolerance:±0.1)
(Recommend min.Dimension)(bottom view)

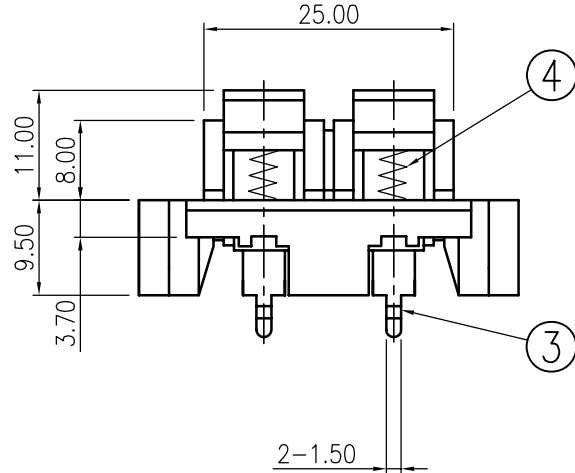

4	SPRING	2	SWA	ø0.55	
3	CONTACT	2	Brass	t=0.6	
2	PUSH PLATE	2	PBT+GF	UL 94V-0	
1	HOUSING	1	PBT+GF	UL 94V-0	

LTR	PART NO.	QTY	MATERIAL	REMARK
120~315	±0.5	DWN	JACKY	DATE 2009.06.22
30~120	±0.35	DSND	JACKY	DATE 2009.06.22
6~30	±0.22	CHKD	DICK	DATE 2009.06.22
BELOW 6	±0.16	APVD	DICK	DATE 2009.06.22

DIMENSION	TOLERANCE	KUNMING ELECTRONICS CO.,LTD.		DWN.NO.	1/1
				A-102SH1P	001

UNLESS OTHERWISE SPECIFIED, TOLERANCE ON DECIMAL: ±0.3 FRACTIONS: ANGLES: ±5°