

REVISIONS					
LTR	DESCRIPTION	DATE	REV.	CHKD.	APVD.
△x0	Outer Contact solder tail is modified.	2012.04.17	黃健璋	郭素玲	郭遠峰
△x1	Solder tail is moified.(ECR No.C03120407)	2012.08.03	黃健璋	郭素玲	郭遠峰
△x2	Modify the structure of product.(ECR C03140518)	2014.06.04	黃健璋	郭素玲	郭遠峰

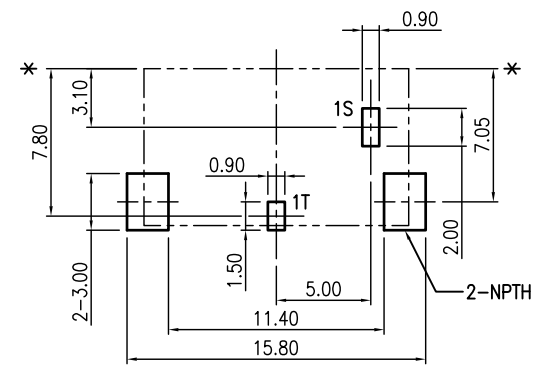

PCB Layout Dimension (Tolerance: ±0.05)
(Recommend min. Dimension)(Bottom View)

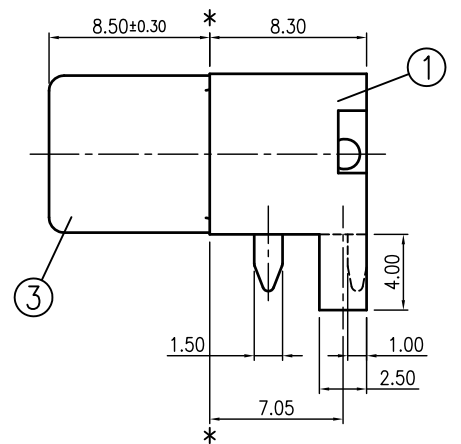
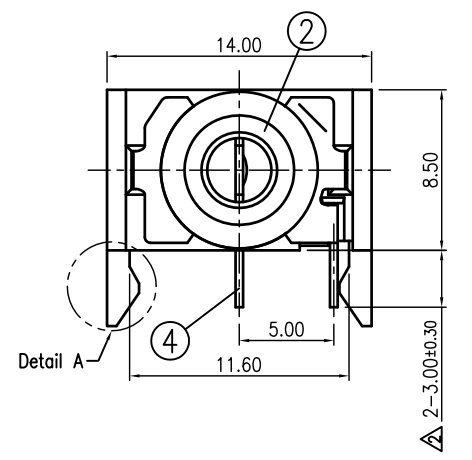
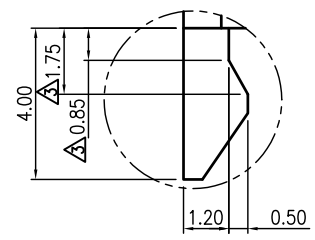
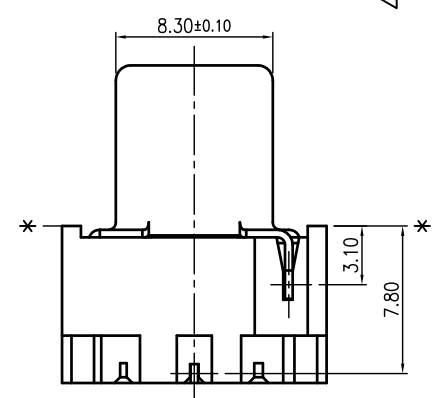

Detail A
Scale:2:1

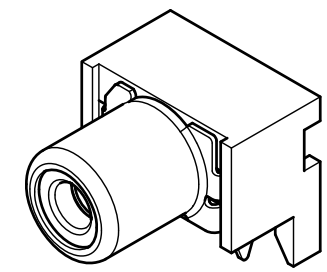
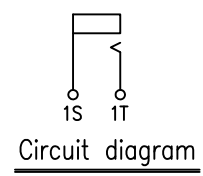

4	CENTER CONTACT(1T)	1	Brass t=0.40	Please refer to color and plating combination list.
3	OUTER CONTACT(1S)	1	Ferro alloy t=0.40	
2	WASHER	1	PBT+GF UL 94V-0	
1	HOUSING	1	PBT+GF UL 94V-0	

LTR	PART NAME	Q'TY	MATERIAL	REMARK
120~315	±0.50	DWN	黃健璋	DATE 2012.03.15
30~120	±0.35	DSND	黃健璋	DATE 2012.03.15
6~30	±0.22	CHKD	郭遠峰	DATE 2012.03.15
BELOW 6	±0.16	APVD	郭遠峰	DATE 2012.03.15
DIMENSION TOLERANCE				KUNMING ELECTRONICS CO.,LTD.
				SCALE 2.5/1
				PROJECTION
				UNIT:mm
				NAME PIN JACK
				CAT. NO. KM04098BSF-__P
				DWN.NO. A-04098BSFP
				1/1
				004

SONY specifies the raw material is SS-00259 the latest version of document requests, and purchased from the SONY specified raw materials suppliers.