

1 2 3 4 5 6

REVISIONS					
LTR	DESCRIPTION	DATE	REV.	CHKD.	APVD.

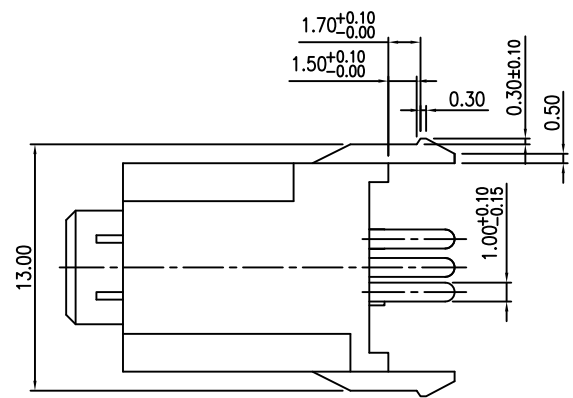
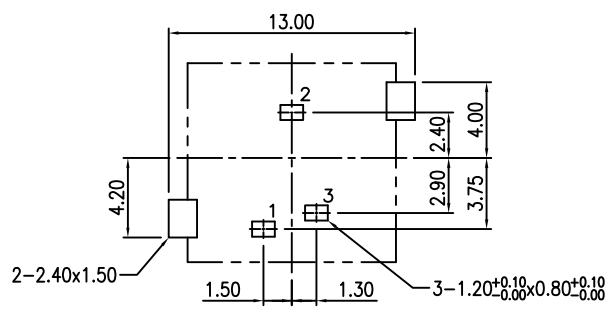
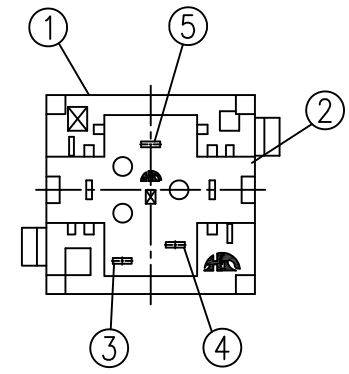
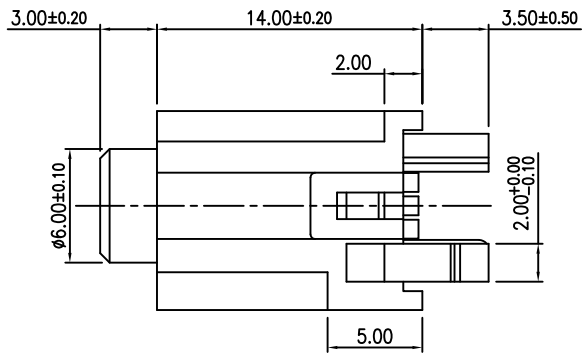
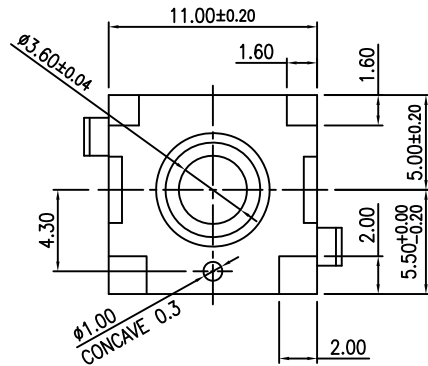

MODEL NO.	HTJ-035-28D__PP
SCHMATIC	

PCB Layout Dimension (Tolerance:±0.10)  
(Recommend min. Dimension)(Bottom View)

LTR	PART NAME	Q'TY	MATERIAL	REMARK
5	TIP SPRING (2)	1	Copper Alloy t=0.30	Please refer color combination list
4	RING SPRING (3)	1	Copper Alloy t=0.30	
3	EARTH SPRING (1)	1	Copper Alloy t=0.30	
2	COVER	1	POM UL 94HB	
1	HOUSING	1	PBT+GF UL 94V-0	

LTR	TOLERANCE	DATE	SCALE	PROJECTION	UNIT:mm	NAME	DWN.NO.	1/1
120~315	±0.50	DWN 陳衛兵	2015.12.17	2.5/1	mm	MINIATURE JACK	A-03528DP	001
30~120	±0.35	DSND 劉怡廷	1998.05.28					
6~30	±0.22	CHKD 張啟濤	2015.12.17					
BELOW 6	±0.16	APVD 陳宗碧	2015.12.17					
KUNMING ELECTRONICS CO.,LTD.								

UNLESS OTHERWISE SPECIFIED, TOLERANCE ON DECIMAL:±0.30 ANGLES:±5°

The raw material specified by Sony should meet SS-00259 requirement of the latest version. When such material is used, it should be supplied by Sony designated suppliers.