

REVISIONS

LTR	DESCRIPTION	DATE	REV.	CHKD.	APVD.
△x1	To modify the material.(CEN070032)	2012.09.17	銀 晶	張啓濤	郭素玲
△x1	To revise the drawing by official letter.(C0803001)	2012.09.17	銀 晶	張啓濤	郭素玲

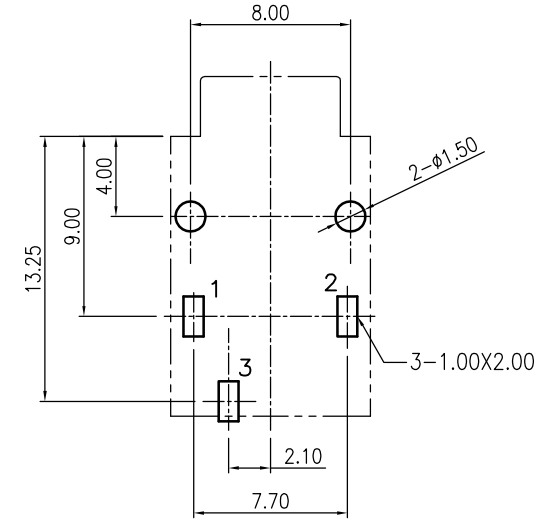

PCB Layout Dimension (Tolerance: ± 0.10)
(Recommend min. Dimension)(Bottom View)

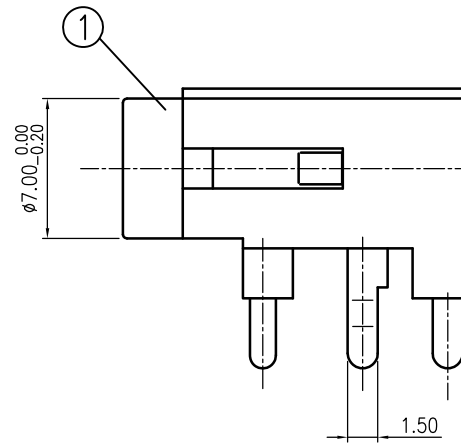
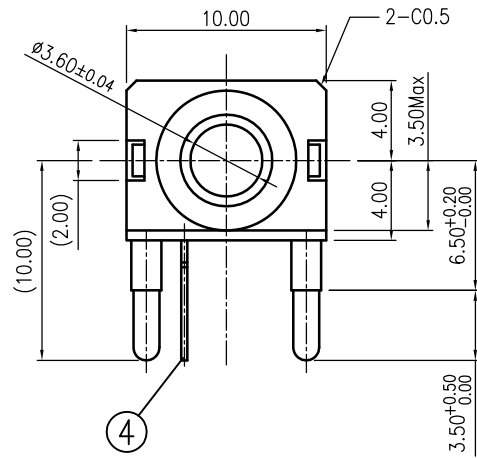
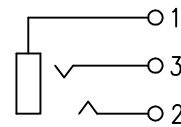
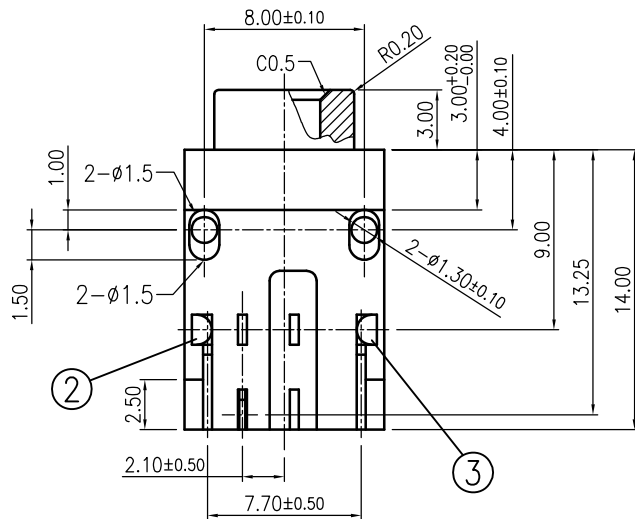

Schematic

△	4	RING SPRING (3)	1	Copper Alloy t=0.30	Please refer color and plating combination list.
△	3	TIP SPRING (2)	1	Copper Alloy t=0.30	
	2	EARTH SPRING (1)	1	Copper Alloy t=0.30	
	1	HOUSING	1	ABS UL 94-HB	

LTR	PART NAME	Q'TY	MATERIAL	REMARK
120~315	± 0.5	DWN	劉望全	DATE 2005.08.03
30~120	± 0.35	DSND	李侃侃	DATE 2005.08.03
6~30	± 0.22	CHKD	夏正雄	DATE 2005.08.04
BELOW 6	± 0.16	APVD	楊仲民	DATE 2005.08.04
DIMENSION	TOLERANCE	KUNMING ELECTRONICS CO.,LTD.		

SCALE 2.5/1
PROJECTION
UNIT: mm

NAME MINIATURE JACK
CAT. NO. HTJ-035-22D
DWN.NO. A-03522D
1/1
B