

REVISIONS					
LTR	DESCRIPTION	DATE	REV.	CHKD.	APVD.
△x1	To revise the drawing by official letter.(C803001)	2011.05.17	汪 鑫	張啓濤	郭素玲

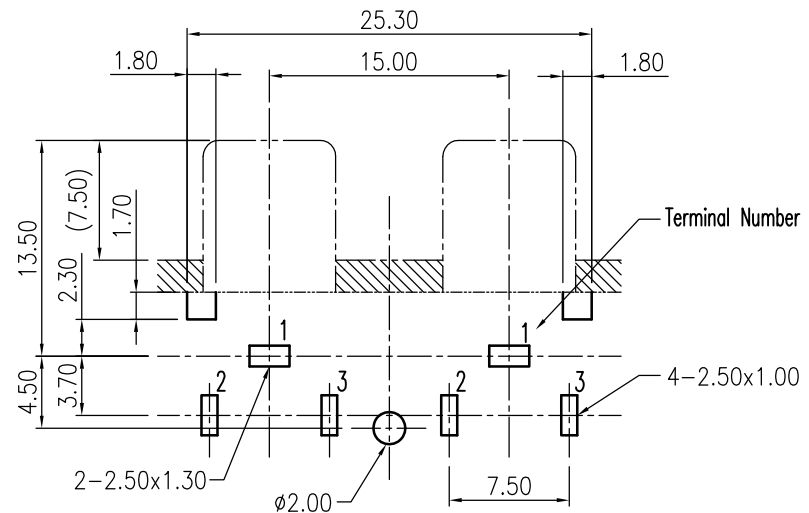

T:1.60 PCB Layout Dimension (Tolerance:±0.10)
(Recommend min. Dimension)(Bottom View)

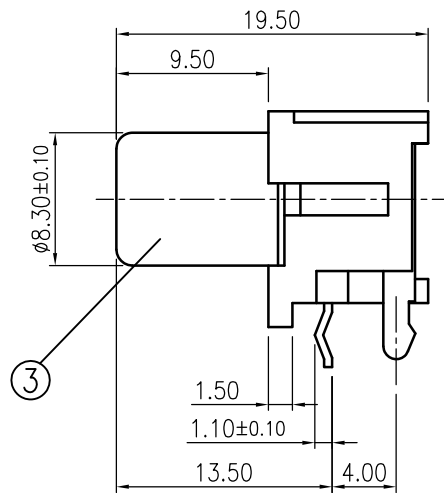
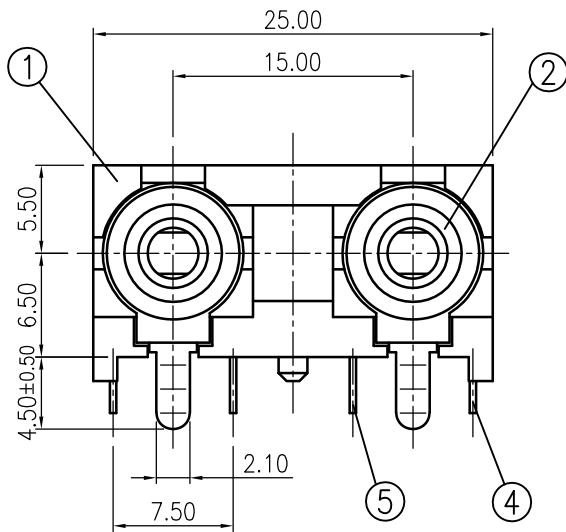
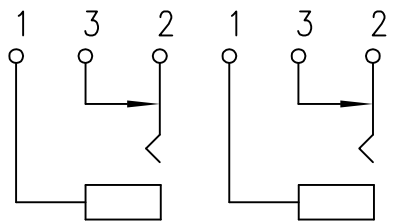

Schematic

LTR	PART NAME	Q'TY	MATERIAL	REMARK
5	TIP SPRING	2	Copper Alloy t=0.30	Please refer color and plating combination list.
4	SHUNT SPRING	2	Brass t=0.40	
3	OUTER CONTACT	2	Brass t=0.40	
2	WASHER	2	POM UL 94HB	
1	HOUSING	1	PBT+GF UL 94V-0	

DIMENSION	TOLERANCE	LTR	PART NAME	Q'TY	MATERIAL	REMARK
120~315	±0.5	DWN	闕雄浪	DATE	2005.12.05	NAME PIN JACK
30~120	±0.35	DSND	劉望全	DATE	2005.12.05	
6~30	±0.22	CHKD	江溢得	DATE	2005.12.05	CAT. NO. HTJ-032-25A-__P
BELOW 6	±0.16	APVD	楊仲民	DATE	2005.12.05	
KUNMING ELECTRONICS CO.,LTD.						DWN.NO. A-03225AP
						1/1
						B

UNLESS OTHERWISE SPECIFIED, TOLERANCE ON DECIMAL:±0.30 ANGLES: ±5°