

| REVISIONS | | | | | |
|-----------|---|------------|------|-------|-------|
| LTR | DESCRIPTION | DATE | REV. | CHKD. | APVD. |
| △x1 | Update the approved standard(ECR C03140514) | 2014.04.24 | 黃健璋 | 郭素玲 | 郭遠峰 |
| △x1 | To change the mark of housing (ECR C03150547) | 2015.07.08 | 陳衛兵 | 張啟濤 | 陳宗碧 |
| △x2 | Cancel the Semko (ECR No.C03150560) | 2015.11.10 | 李阮龍 | 郭遠峰 | 郭遠峰 |
| △x2 | Cancel the VDE mark (VDE Reference No)(ECR C03190596) | 2019.06.28 | 李阮龍 | 李阮龍 | 郭遠峰 |

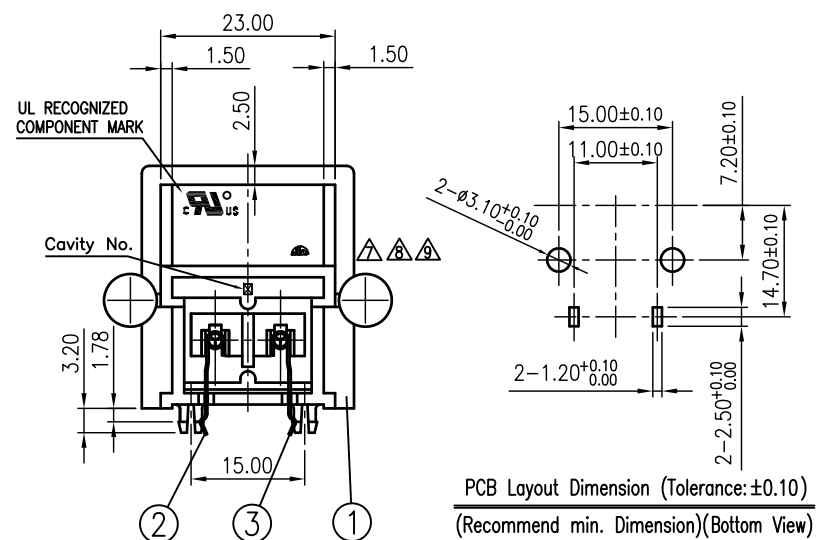

Note:
 △△△ Approved Standard: UL&cUL FILE NO.E95834

| 3 | PIN-2 | 1 | C2680 t=0.30 | MBCu2μm-Sn3μm |
|---------------------|-----------|------|--------------|------------------------------|
| 2 | PIN-1 | 1 | C2680 t=0.30 | MBCu2μm-Sn3μm |
| 1 | HOUSING | 1 | PPO UL 94V-1 | |
| LTR | PART NAME | Q'TY | MATERIAL | REMARK |
| 120~315 | ±0.50 | DWN | 鄭伍豐 | DATE 2008.03.08 |
| 30~120 | ±0.35 | DSND | 劉怡廷 | DATE 1998.05.19 |
| 6~30 | ±0.22 | CHKD | 陸昌妹 | DATE 2008.03.08 |
| BELOW 6 | ±0.16 | APVD | 林倫旋 | DATE 2008.03.08 |
| DIMENSION TOLERANCE | | | | KUNMING ELECTRONICS CO.,LTD. |
| DWN.NO. | | | | A-028-P |
| SCALE | | | | 1/1 |
| PROJECTION | | | | NAME AC POWER SOCKET |
| UNIT:mm | | | | CAT. NO. |
| | | | | HJC-028-P |
| | | | | 1/1 |
| | | | | J-001 |

UNLESS OTHERWISE SPECIFIED, TOLERANCE ON DECIMAL: ±0.30 ANGLES: ±5°

The raw material specified by Sony should meet SS-00259 requirement of the latest version. When such material is used, it should be supplied by Sony designated suppliers.